

Motorschutzbügel Yamaha XJR 1300

Art.-Nr.: 501.4518 00 02 chrom

Art.-Nr.: 501.409 00 02 chrom

Seitenkoffer
Topcases
Gepäckträger
Lock it System
Softbags
Aluminiumkoffer
Lederkoffer
Schutzbügel
Hauptständer
Chopper-Parts
Quad-Parts
Accessoires



Montage

Stück	Bestellnr.	Bezeichnung
1	704.513 HB	Motorschutzbügel links
1	704.514 HB	Motorschutzbügel rechts
1	704.515 HB	Versteifungsstrebe (M8 Innengewinde)
4	150.914	Inbusschraube M8 x 50
2	150.908	Inbusschraube M8 x 20
2	151.112	Rohrschellen ø42 x 71
10	150.810	U-Scheibe ø8,4
8	150.805	Sprengring ø8,4
4	150.825	Distanz ø18 x ø9 x 20
4	150.895	Hutmutter, verchromt M 8
2	704.285	verchromte Halteplättchen

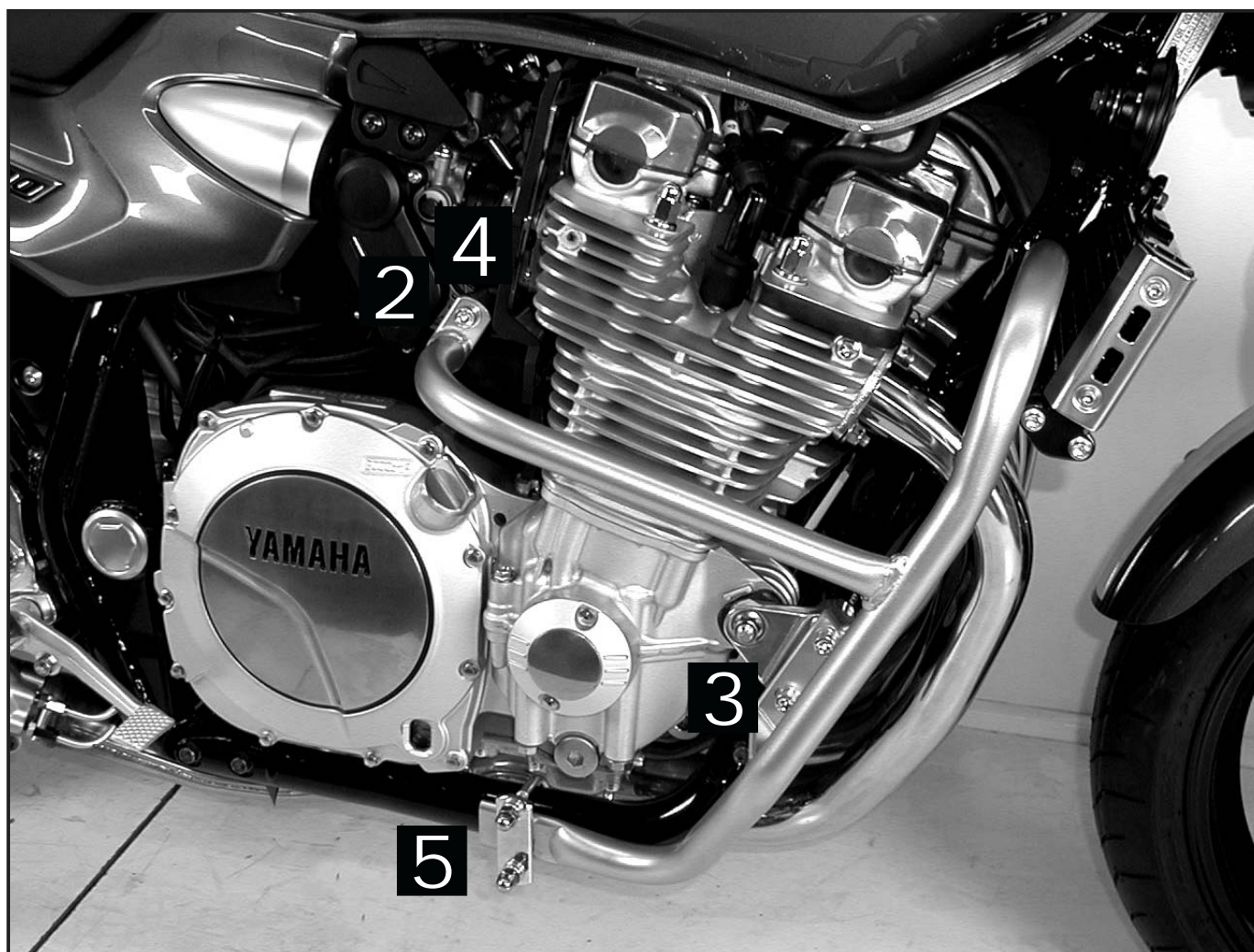

Motorschutzbügel Yamaha XJR 1300

Art.-Nr.: 501.4518 00 02 chrom
Art.-Nr.: 501.409 00 02 chrom

Seitenkoffer
Topcases
Gepäckträger
Lock it System
Softbags
Aluminiumkoffer
Lederkoffer
Schutzbügel
Hauptständer
Chopper-Parts
Quad-Parts
Accessoires



Montage

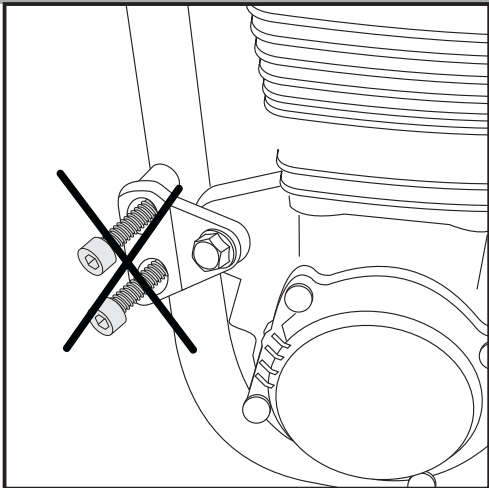

1

Vorbereitung:

Demontieren sie die Schrauben am vorderen Rahmenbefestigungspunkt. Die Originalschrauben entfallen.

ACHTUNG:

Nicht auf beiden Seiten gleichzeitig die Originalschrauben entfernen!

Tipp:

Schrauben sie alle Teile an und lassen sie die zugänglichen Schrauben etwas locker. Nachdem alles montiert ist, werden alle Schrauben auf das entsprechende Anzugsmoment angezogen. Dadurch wird sichergestellt, dass das Produkt spannungsfrei angebaut ist. So ist eine lange Lebensdauer sichergestellt!

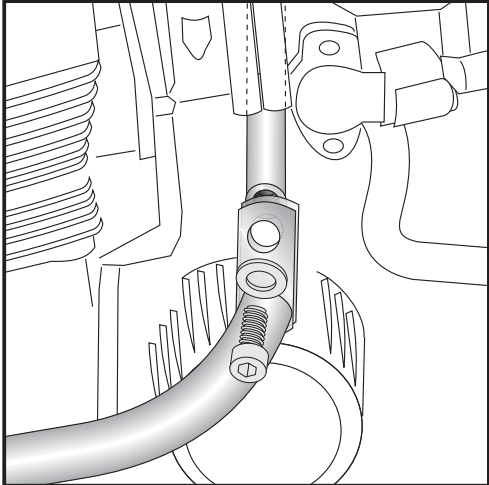

2

Montieren der Versteifungstrebe:

vor Anbau des Motorschutzbügels an der Lasche des linken Bügels mit der Inbusschraube M8 x 20 und einer U-Scheibe $\varnothing 8,4$ montieren. Stecken Sie den so vorbereiteten Bügel unter der Einspritzanlage bzw. neben dem Vergaser und hinter dem Motorblock durch.

ACHTUNG bei Art.-Nr.: 501.409 00 02: Achten Sie beim Durchstecken darauf, den Temperaturfühler am Vergaser nicht zu beschädigen und das nach der Montage der Bügel nicht am Temperaturfühler anliegt.

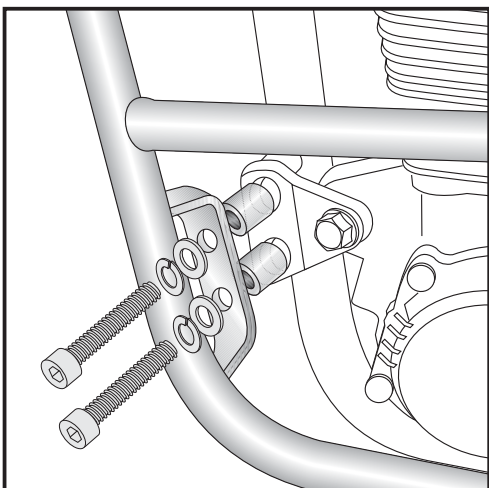

3

Montage des Motorschutzbügels vorne links und rechts:

In die freien Bohrungen der Originalschrauben werden jeweils die Aludistanzen $\varnothing 18 \times \varnothing 9 \times 20$ eingesetzt.

Der Motorschutzbügel wird mit den Inbusschrauben M8 x 50, Sprengringen $\varnothing 8,4$ und U-Scheiben $\varnothing 8,4$ montiert.



**Motorschutzbügel
Yamaha XJR 1300**

Art.-Nr.: 501.4518 00 02 chrom
Art.-Nr.: 501.409 00 02 chrom

Seitenkoffer
Topcases
Gepäckträger
Lock it System
Softbags
Aluminiumkoffer
Lederkoffer
Schutzbügel
Hauptständer
Chopper-Parts
Quad-Parts
Accessoires



Montage

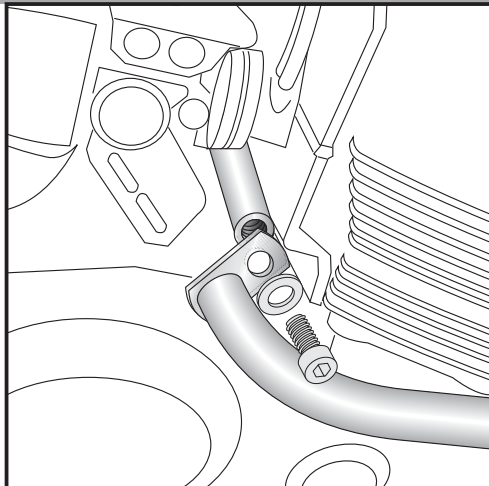

4

Montieren der Versteifungstrebe:

Verbinden sie den rechten Motorschutzbügel und die Versteifungstrebe mit einer weiteren Inbusschraube M8 x 20 und einer U-Scheibe ø8,4.

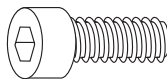

je 1x

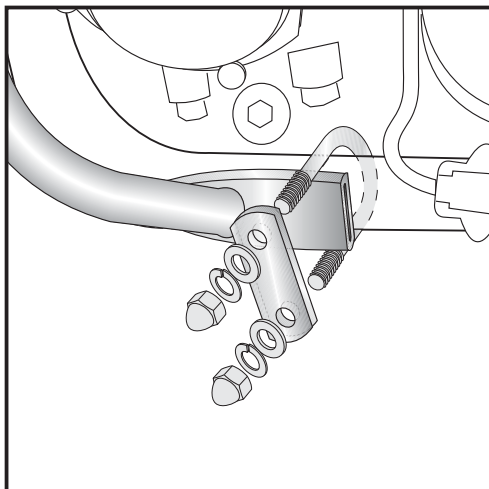

5

Montage des Motorschutzbügels unten links und rechts:

Der Motorschutzbügel wird mit Rohrschellen am Rahmen verschraubt. Dazu die Rohrschellen ø42 x 17 über den Rahmen schieben und mit den Halteplättchen, U-Scheiben ø8,4, Sprengringen ø8,4 und den Hutmuttern M8 montieren.

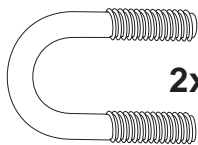

2x

je 4x



**Anzugsmomente des Motorradherstellers beachten!
Nach der Montage alle Verschraubungen auf festen Sitz kontrollieren!
Bitte beachten Sie unsere beigefügten Serviceinformationen.**

Als weiteres Zubehör lieferbar:

Komplettträger schwarz (mit Gepäckbrücke):

Komplettträger chrom (mit Gepäckbrücke):

Komplettträger schwarz "Lock it System" (mit Gepäckbrücke):

Gepäckbrücke schwarz:

Gepäckbrücke chrom:

Modell Bj.2004-2006, Modell bis Bj.2003

Modell Bj.2004-2006, Modell bis Bj.2003

Modell ab Bj.2007, Modell Bj.2004-2006

Modell ab Bj.2007, Modell Bj.2004-2006, Modell bis Bj.2003

Modell Bj.2004-2006, Modell bis Bj.2003



**Hepco & Becker GmbH
An der Steinmauer 6**

D-66955 Pirmasens

Tel.: 06331 - 1453 - 100

Fax: 06331 - 1453 - 120

eMail: vertrieb@hepco-becker.de

www.hepco-becker.de

Engine guard
Yamaha XJR 1300

Item-No.
501.4518 00 02 chrome
501.409 00 02 chrome

Side cases
Top cases
luggage frames
Lock it system
Softbags
Aluminium luggage
Leather luggage
Protection bars
Center stands
Chopper parts
Quad parts
Accessories



Assembling instructions

The kit includes the following parts:

Quant	item no.	description
1	704.513 HB	engine guard left
1	704.514 HB	engine guard right
1	704.515 HB	bracing bow
4	150.914	allen screw M8 x 50
2	150.908	allen screw M8 x 20
2	151.112	u-shaped clamp ø42 x 71
10	150.810	washer ø8,4
8	150.805	lock ring ø8,4
4	150.825	spacer ø18 x ø9 x 20
4	150.895	cup nut, chromed M 8
2	704.285	metal adapter, chromed

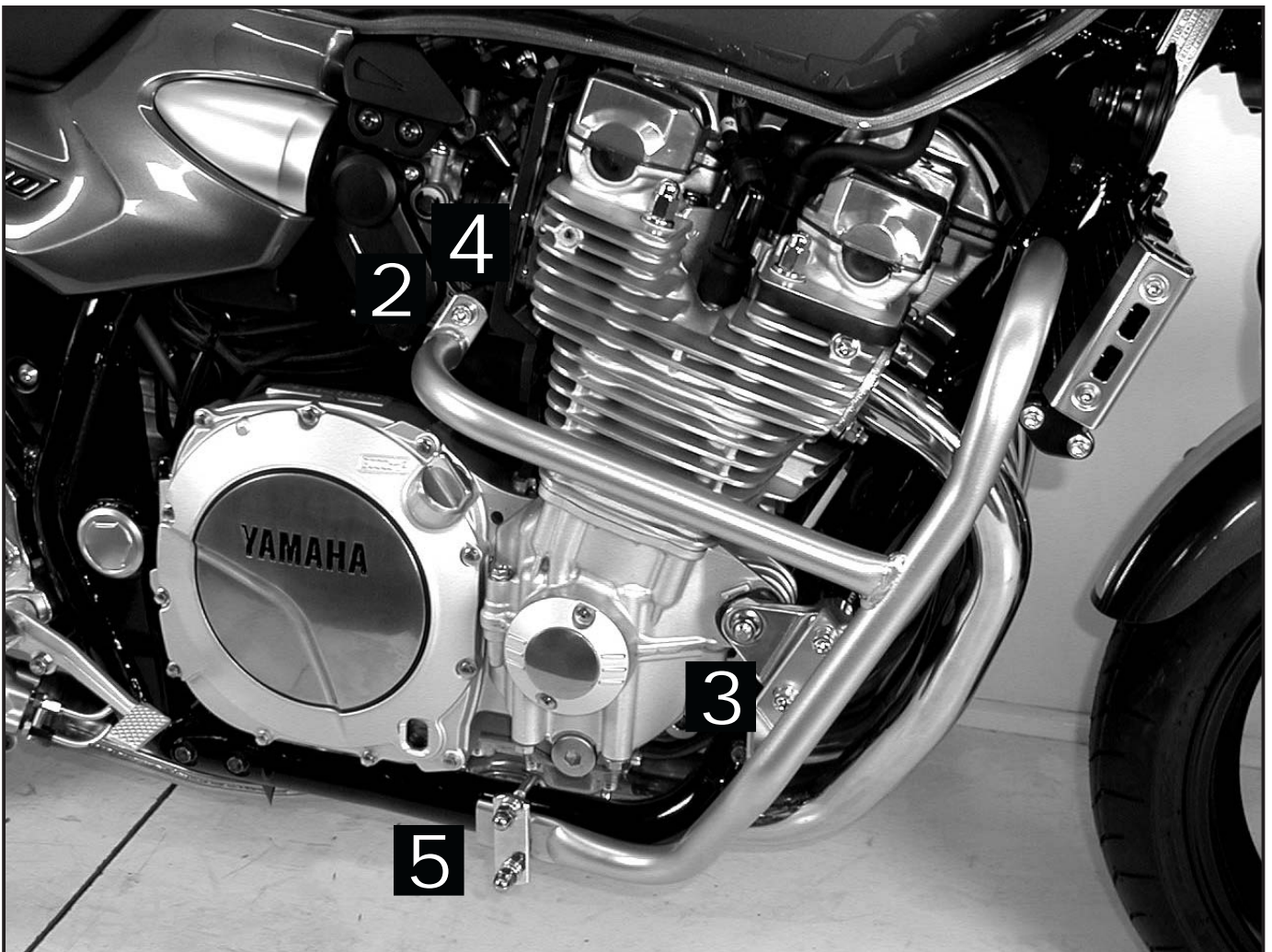

Engine guard
Yamaha XJR 1300

Item-No.
501.4518 00 02 chrome
501.409 00 02 chrome

- Side cases
- Top cases
- luggage frames
- Lock it system
- Softbags
- Aluminium luggage
- Leather luggage
- Protection bars
- Center stands
- Chopper parts
- Quad parts
- Accessories



Assembling instructions

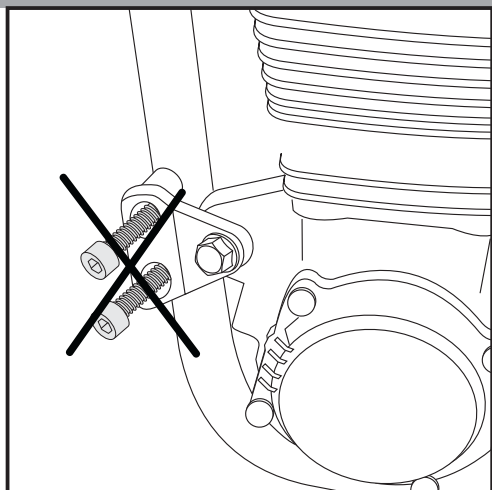

1

Preparing:
Unmount original screws at the frame.
The original screws are not needed any more.

Notice:
Do it side by side, otherwise the engine can move.

Tip:
Fit all parts and screw on not too strong.
After mounting all parts, the screws should be tightened to the torque specified.
This guarantees, that the kit is mounted without tension.

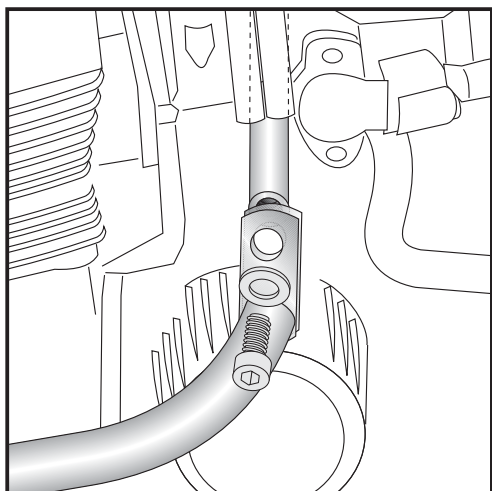

2

Fastening of the bracing bow:
Fix the bracing bow to the left side of the crash bar with allen screw M8 x 20 and washer $\varnothing 8,4$.
Move the crash bar with the bracing bow from the left to the right side, under the fuel injection/the carburetor and behind the engine block.
NOTICE (item-no.: 501.409 00 02): be carefull while inserting through the bracing bow not to destroy the temperature sensor from the carburetor.
After mounting, the bow should not touch the temperature sensor.

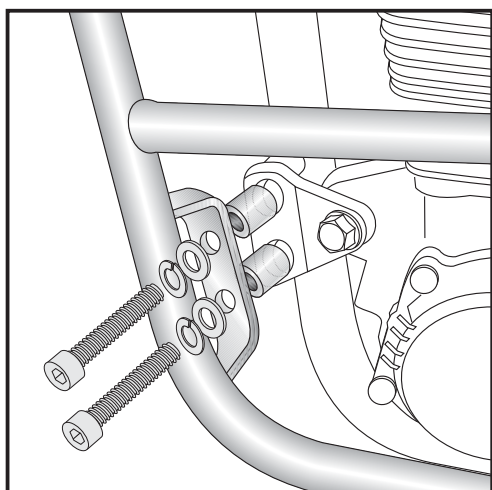
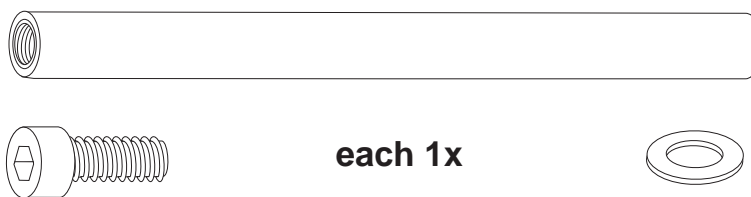

3

Fastening of the crash bar front left + right:
Sandwich spacer $\varnothing 18 \times \varnothing 9 \times 20$ into the free threaded holes and fix the crash bar with allen screw M8 x 50, lock rings $\varnothing 8,4$ and washers $\varnothing 8,4$.



Engine guard
Yamaha XJR 1300

Item-No.
501.4518 00 02 chrome
501.409 00 02 chrome

Side cases
Top cases
luggage frames
Lock it system
Softbags
Aluminium luggage
Leather luggage
Protection bars
Center stands
Chopper parts
Quad parts
Accessories



Assembling instructions

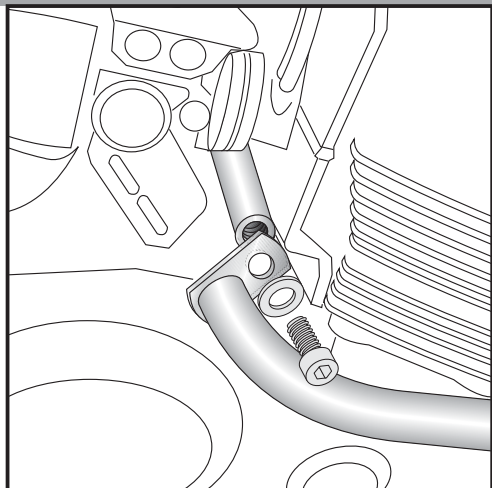

4

Fastening of the bracing bow:
Fix the bracing bow to the right side of the crash bar with allen screw M8 x 20 and washer ø8,4.

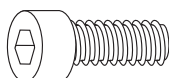

each 1x

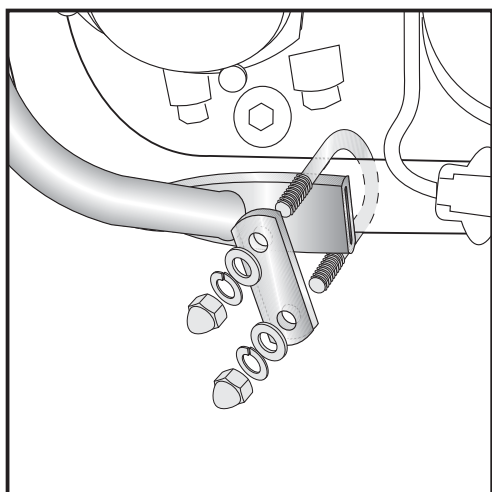

5

Fastening of the crash bar bottom left + right:
The crash bar will be fixed at the frame with u-shaped clamps.
To mount, use metal adapter, chromed, washers ø8,4, lock rings ø8,4 and cup nuts M8.

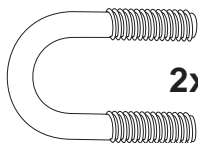

2x

each 4x



Control all screw connections after the assembling for tightness!
Please notice our enclosed service information. All screws, bolts and nuts should be checked after driving the first 50 km to ensure that all are tightened to the proper torque.

Also available:

Side carrier with rear rack, black:

Side carrier with rear rack, chrome:

Side carrier "Lock it System" with rear rack, black:

Rear rack, black:

Rear rack, chrome:

Model 2004-2006, Model up to 2003

Model 2004-2006, Model up to 2003

Model from 2007, Model 2004-2006

Model from 2007, Model 2004-2006, Model up to 2003

Model 2004-2006, Model up to 2003



Hepco & Becker GmbH
An der Steinmauer 6
D-66955 Pirmasens
Germany

Tel.: +49 6331 - 1453 - 100
Fax: +49 6331 - 1453 - 120
eMail: vertrieb@hepco-becker.de
www.hepco-becker.de