

PORTAVALIGIA SPECIFICO - SPECIFIC CASE HOLDER  
 PORTE-VALISE SPECIFIQUE - SPEZIFISCHER KOFFER-TRÄGER  
 PORTA-EQUIPAJE ESPECIFICO

# YAMAHA FJR1300 2006

ISTRUZIONI DI MONTAGGIO - MOUNTING INSTRUCTIONS  
 INSTRUCTIONS DE MONTAGE - BAUANLEITUNG - INSTRUCCIONES DE MONTAJE

1



**SUPPORTO**  
 SUPPORT  
 HALTERUNG  
 SOPORTE

Q.TY n.1

2

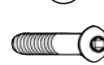

**VITE TBEI M8x20mm**  
 SCREW M8x20mm  
 VIS M8x20mm  
 SCHRAUBE M8x20mm  
 TORNILLO M8x20mm

Q.TY n.2

3

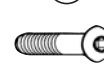

**VITE TBEI M8x45mm**  
 SCREW M8x45mm  
 VIS M8x45mm  
 SCHRAUBE M8x45mm  
 TORNILLO M8x45mm

Q.TY n.2

4



**VITE TBEI M8x35mm**  
 SCREW M8x35mm  
 VIS M8x35mm  
 SCHRAUBE M8x35mm  
 TORNILLO M8x35mm

Q.TY n.1

5

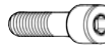

**VITE TCEI M6x25mm**  
 SCREW M6x25mm  
 VIS M6x25mm  
 SCHRAUBE M6x25mm  
 TORNILLO M6x25mm

Q.TY n.4

6



**RONDELLA Ø6mm**  
 WASHER Ø6mm  
 RONDELLE Ø6mm  
 SCHEIBE Ø6mm  
 ARANDELA Ø6mm

Q.TY n.4

7



**RONDELLA Ø6x18mm**  
 WASHER Ø6x18mm  
 RONDELLE Ø6x18mm  
 SCHEIBE Ø6x18mm  
 ARANDELA Ø6x18mm

Q.TY n.4

8



**DISTANZIALE Ø22x21mm**  
 Foro Ø8,5mm, V596

SPACER  
 ENTRETOISE  
 DISTANZSTUECK  
 DISTANCIADOR

Q.TY n.1

9



**DISTANZIALE Ø22x31mm**  
 Foro Ø8,5mm, V516

SPACER  
 ENTRETOISE  
 DISTANZSTUECK  
 DISTANCIADOR

Q.TY n.2

10



**PIASTRA MONOKEY**  
 Z621M

PLATE  
 PLATINE  
 PLATTE  
 PARRILLA

Q.TY n.1

11



**COPRIFORO**  
 Z621

BOLT CAP  
 CACHE TROU  
 STOPLOCK  
 TAPA AGUJERO

Q.TY n.6

12



**DADO A.B. M6**  
 BOLT M6  
 ECROU M6  
 MUTTER M6  
 TUERCA M6

Q.TY n.4

13



**GOMMA SAGOMATA**  
 6 cm, Z1591

RUBBER CUSHION  
 CAOUTCHOUC PROFILE  
 GEFORMTE GUMMI  
 GOMA PROTECTORA

Q.TY n.1

14



**RONDELLA Ø8x14mm**  
 WASHER Ø8x14mm  
 RONDELLE Ø8x14mm  
 SCHEIBE Ø8x14mm  
 ARANDELA Ø8x14mm

Q.TY n.5

**ATTENZIONE**  
 PESO MASSIMO SOPPORTABILE DAL PORTAPACCO  
 10Kg.

**WARNING**  
 MAX. LOADING OF THE CARRIER 10Kg. (21lbs)

**ATTENTION**  
 CHARGE MAXIMALE 10Kg.

**ACHTUNG**  
 MAXIMALE BELASTUNG DES TRÄGERS 10Kg.

**¡ATENCIÓN!**  
 CARGA MÁXIMA AUTORIZADA 10Kg.

A

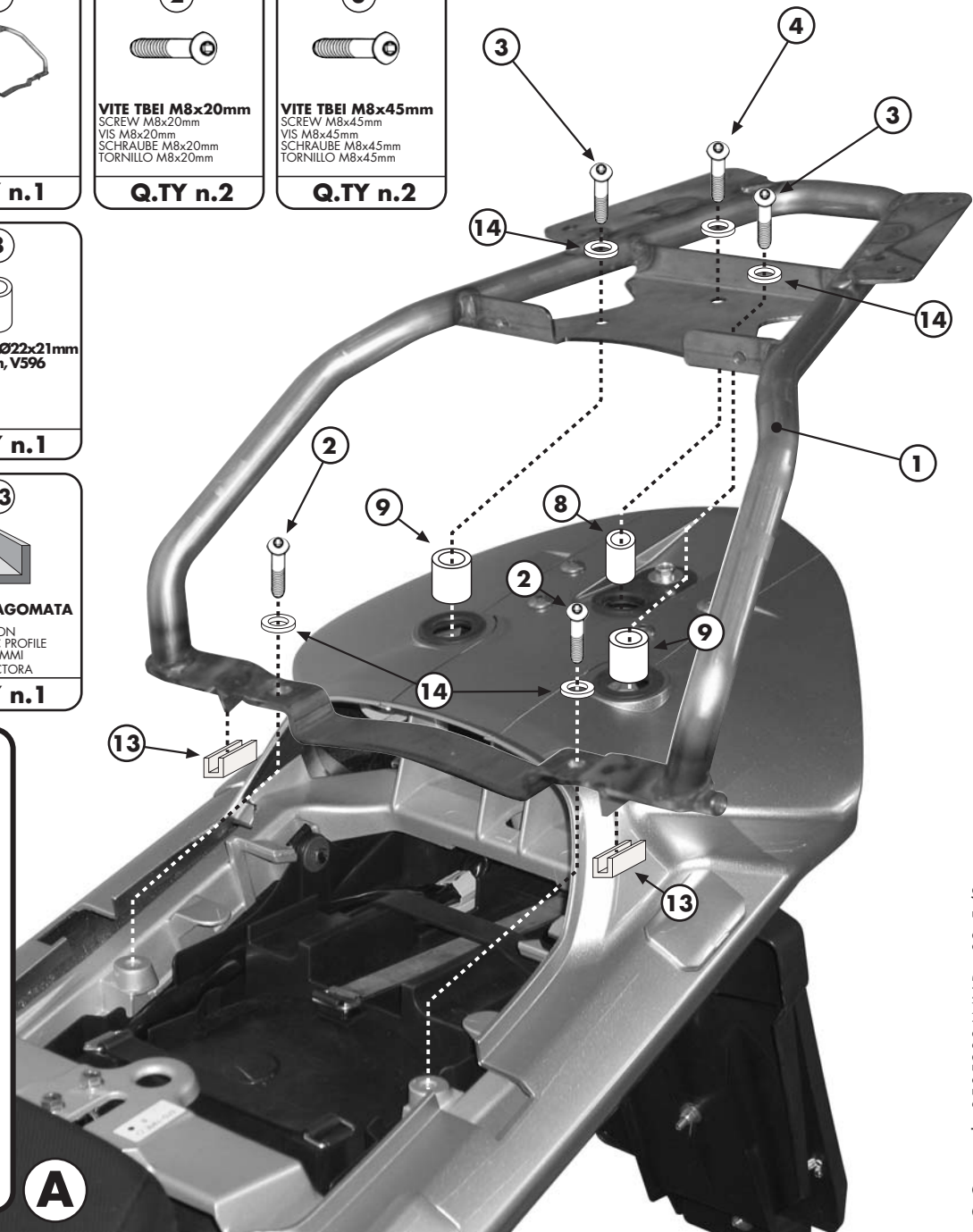

PORTAVALIGIA SPECIFICO - SPECIFIC CASE HOLDER  
PORTE-VALISE SPECIFIQUE - SPEZIFISCHER KOFFER-TRÄGER  
PORTA-EQUIPAJE ESPECIFICO

# YAMAHA FJR1300 2006

ISTRUZIONI DI MONTAGGIO - MOUNTING INSTRUCTIONS  
INSTRUCTIONS DE MONTAGE - BAUANLEITUNG - INSTRUCCIONES DE MONTAJE

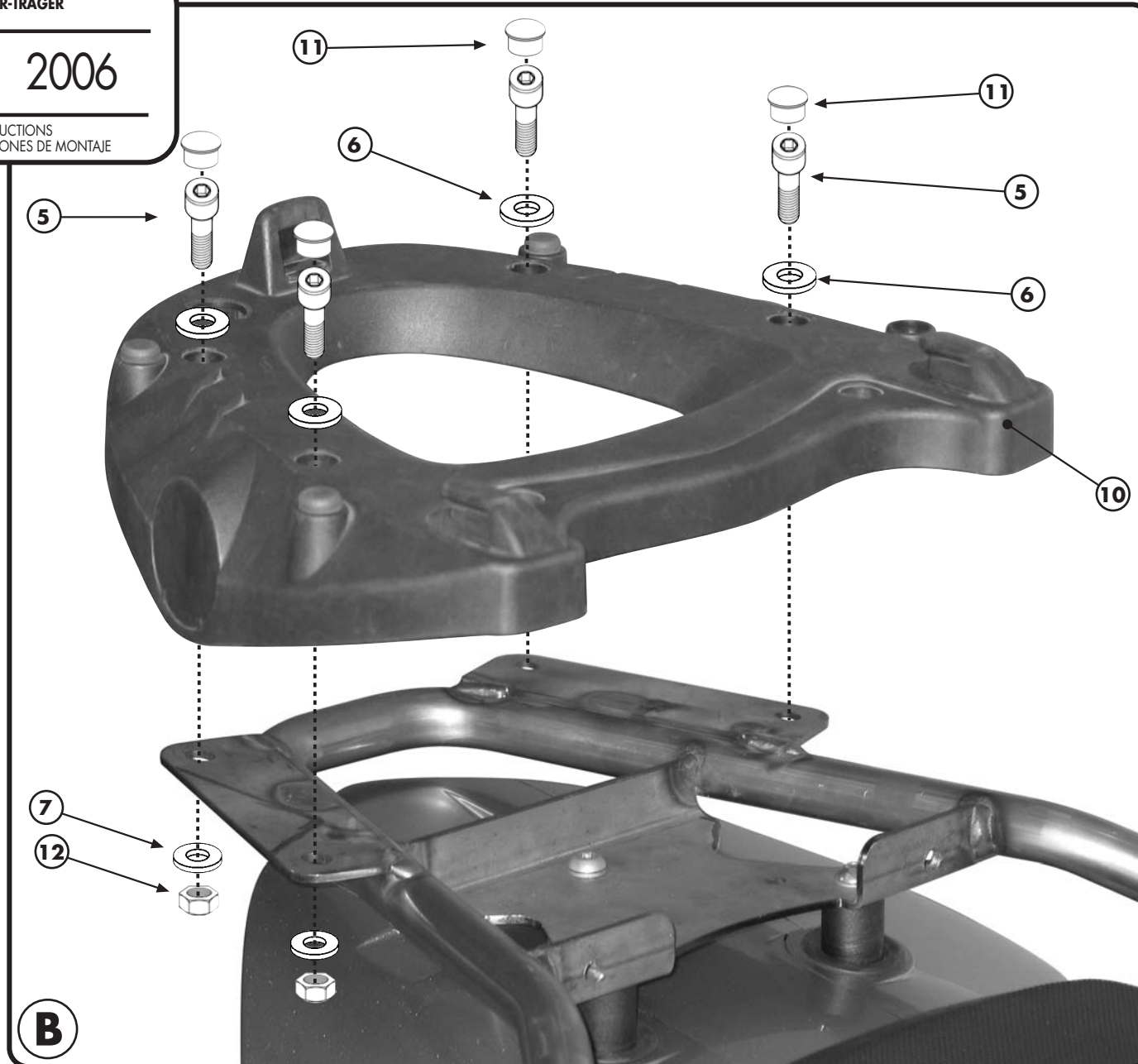

PORTAVALIGIA SPECIFICO - SPECIFIC CASE HOLDER  
 PORTE-VALISE SPECIFIQUE - SPEZIFISCHER KOFFER-TRÄGER  
 PORTA-EQUIPAJE ESPECIFICO

**YAMAHA FJR1300 2006**

ISTRUZIONI DI MONTAGGIO - MOUNTING INSTRUCTIONS  
 INSTRUCTIONS DE MONTAGE - BAUANLEITUNG - INSTRUCCIONES DE MONTAJE

## I ISTRUZIONI DI MONTAGGIO

1. SMONTARE IL MANIGLIONE ORIGINALE;
2. MONTARE IL PORTAVALIGIA POSTERIORE COME INDICATO IN FOTOGRAFIA A E B; FARE ATTENZIONE AL POSIZIONAMENTO DELLE PROTEZIONI IN GOMMA N°13, COME INDICATO IN FOTOGRAFIA A;
3. ULTIMARE IL MONTAGGIO VERIFICANDO CHE TUTTE LE VITI SIANO SERRATE BENE E CHE IL TAPPO ANTIFURTO ED I GOMMINI SIANO MONTATI CORRETTAMENTE SULLA PIASTRA.

## GB MOUNTING INSTRUCTIONS

1. REMOVE THE ORIGINAL GRAB RAILS;
2. MOUNT THE TOP-CASE CARRIER AS SHOWN IN PICTURES A AND B; PAYING PARTICULAR ATTENTION IN ORDER TO PLACE THE RUBBER PROTECTION N°13 CORRECTLY AS SHOWN IN PICTURE A;
3. LASTLY CHECK THAT ALL SCREWS HAVE BEEN TIGHTENED AND THAT THE RUBBERS AND THE ANTI-THEFT CAP HAVE BEEN CORRECTLY POSITIONED ON THE PLATE.

## F INSTRUCTIONS DE MONTAGE

1. DEMONTER LA POIGNEE D'ORIGINE ;
2. MONTER LE SUPPORT TOP CASE COMME INDIQUE EN PHOTOS A ET B ; FAIRE ATTENTION AU POSITIONNEMENT DES PROTECTIONS EN GOMME N°13 COMME MONTRE EN PHOTO A ;
3. TERMINER LE MONTAGE EN CONTROLANT LE BON SERRAGE DE TOUTES LES VIS AINSI QUE LA MISE EN PLACE DU BOUCHON ANTIVOL ET DES SILENT BLOCS SUR LA PLATINE.

## D BAUANLEITUNG

1. ENTFERNEN SIE DEN ORIGINAL HANDGRIFF;
2. MONTIEREN SIE DEN KOFFERTRÄGER WIE IN DEN BILDERN A UND B BESCHRIEBEN; POSITIONIEREN SIE DIE GUMMISCHUTZE NR. 13 WIE IM BILD A BESCHRIEBEN;
3. ZULETZT ÜFCBERPRÜFCFEN SIE, DASS ALLE SCHRAUBEN FESTGEZOGEN WURDEN UND DASS DIE GUMMISTO'F6PSEL SOWIE DIE DIEBSTAHSICHERUNG AUF DER PLATTE KORREKT POSITIONIERT WURDEN.

## ES

## INSTRUCCIONES DE MONTAJE

1. DESMONTAR EL ASA ORIGINAL
2. MONTAR EL PORTAEQUIPAJES POSTERIOR TAL Y COMO SE INDICA EN LA FOTOGRAFÍA A Y B; PRESTAR ESPECIAL ATENCIÓN EN EL POSICIONAMIENTO DE LAS GOMAS PROTECTORAS (N°13), TAL Y COMO SE MUESTRA EN LA FOTOGRAFÍA A.
3. ULTIMAR EL MONTAJE VERIFICANDO QUE TODOS LOS TORNILLOS ESTAN BIEN APRETADOS Y QUE EL TAPON ANTIRROBO Y LAS GOMAS ESTAN MONTADAS CORRECTAMENTE EN LA PARRILLA.