



KFT.05.517.100

Revision: 00

## Quick-Lock Seitenkofferträger SUZUKI GSR600

### Montagehinweise

Fahren Sie nicht ohne Koffer mit montierten Seitenplatten. Wenn sie ohne Gepäck fahren, Seitenplatten demontieren.

Alle vom Motorrad gelösten Schrauben sind gemäß Herstellerangaben wieder zu montieren, oder mit von SW-MOTECH gelieferten Schrauben zu ersetzen. Falls nicht anderweitig definiert, diese Schrauben nach Tabelle anziehen.

M6	9,6 Nm
M8	23 Nm
M10	46 Nm

Gegebenenfalls Schrauben mit flüssiger Schraubensicherung einkleben.

Prüfen Sie nach 50 km alle Verbindungen auf festen Sitz.

Maximale Zuladung der Koffer:  
Gemäß Herstellerangaben

SW-MOTECH GmbH & Co. KG  
Bahnhofstrasse 44d  
35282 Rauschenberg  
-Germany-

Tel.: ++ 49 (0) 6425 816 800  
Fax: ++ 49 (0) 6425 816 810

[www.sw-motech.com](http://www.sw-motech.com)

### Mounting Instructions

German safety regulations require that no metal edge with a radius of less than 2.5mm be exposed while driving a motorcycle. Because Quick-Lock sidese cases racks have edges with a radius of less than 2.5mm, Quick-Lock sidese cases racks should not be used when luggage is not attached to them.

SW-MOTECH products should be installed by a qualified, experienced motorcycle technician. If you are unsure of your ability to properly install a product, please have the product installed by your local motorcycle dealer. SW Motech takes no responsibility for damages caused by improper installation.

All screws, bolts and nuts, including all replacement hardware provided by SW-MOTECH, should be tightened to the torque specified in the OEM maintenance manual for your motorcycle. If no torque specifications are provided in the OEM maintenance manual, the following torques may be used:

M6	9,6 Nm
M8	23 Nm
M10	46 Nm

All screws, bolts and nuts should be checked after driving the first 50 km to ensure that all are tightened to the proper torque.

Medium strength liquid thread-locker (i.e., "Loctite") should be used to secure all screws, bolts and nuts.

**!** **20**  Zur Demontage des QUICK-LOCK-Kofferträgers einfach mit einer Münze oder einem Schraubendreher die Schnellverbinder lösen und Seitenträger entfernen!

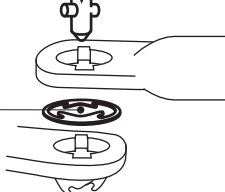
**22** 

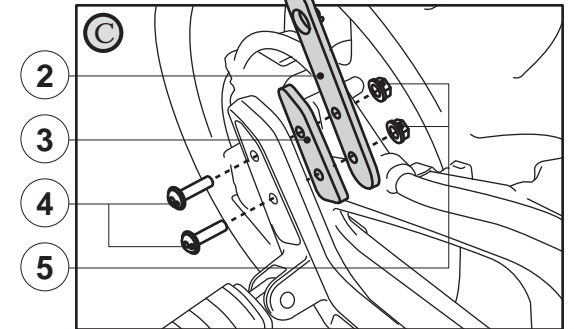
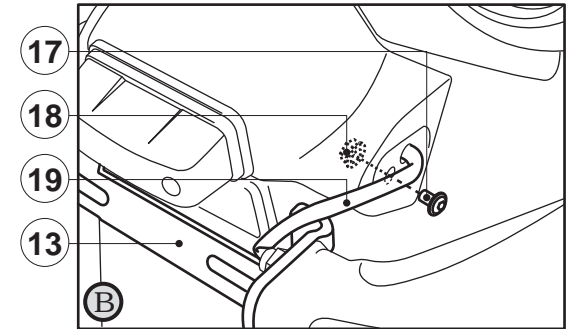
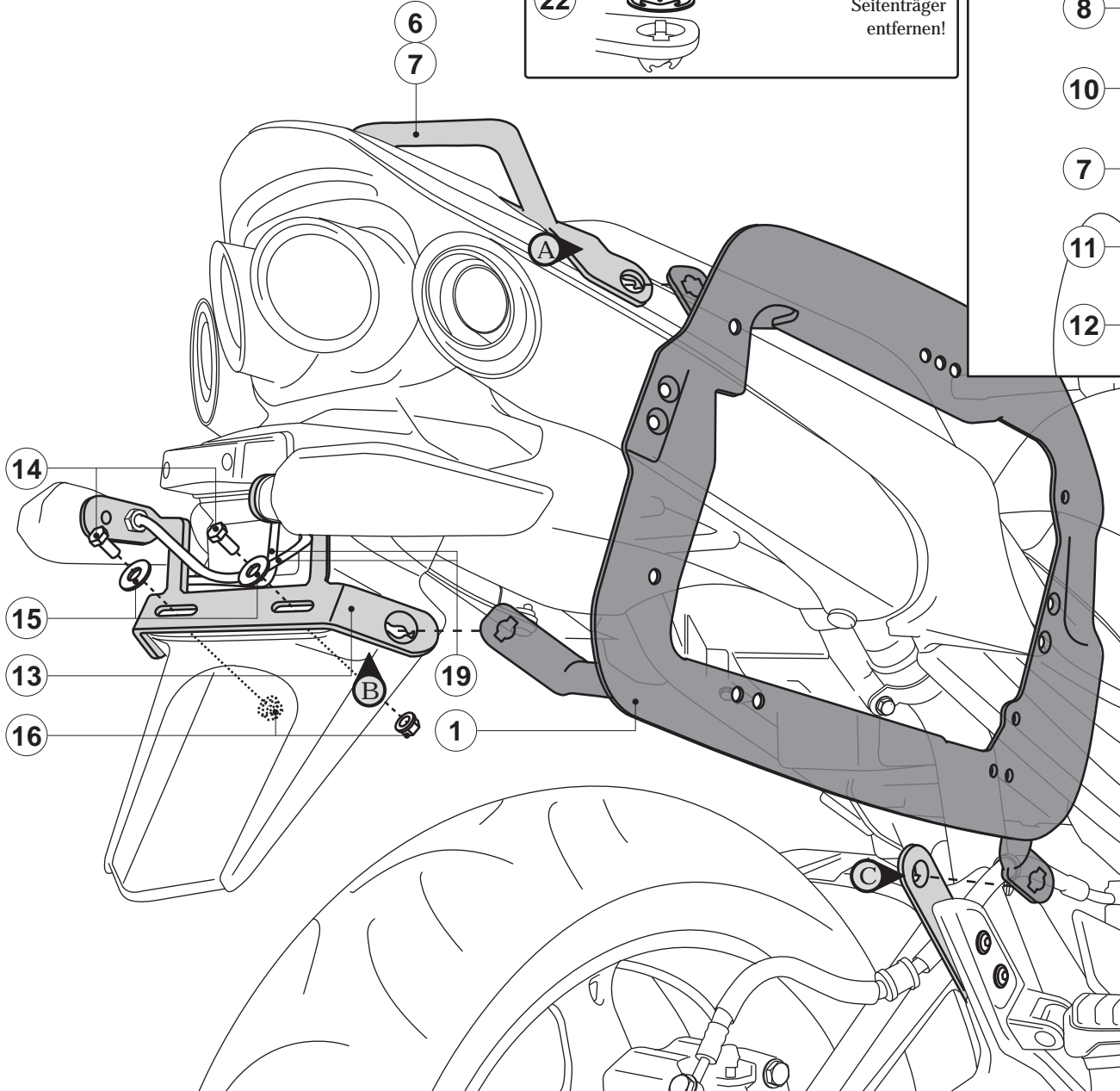
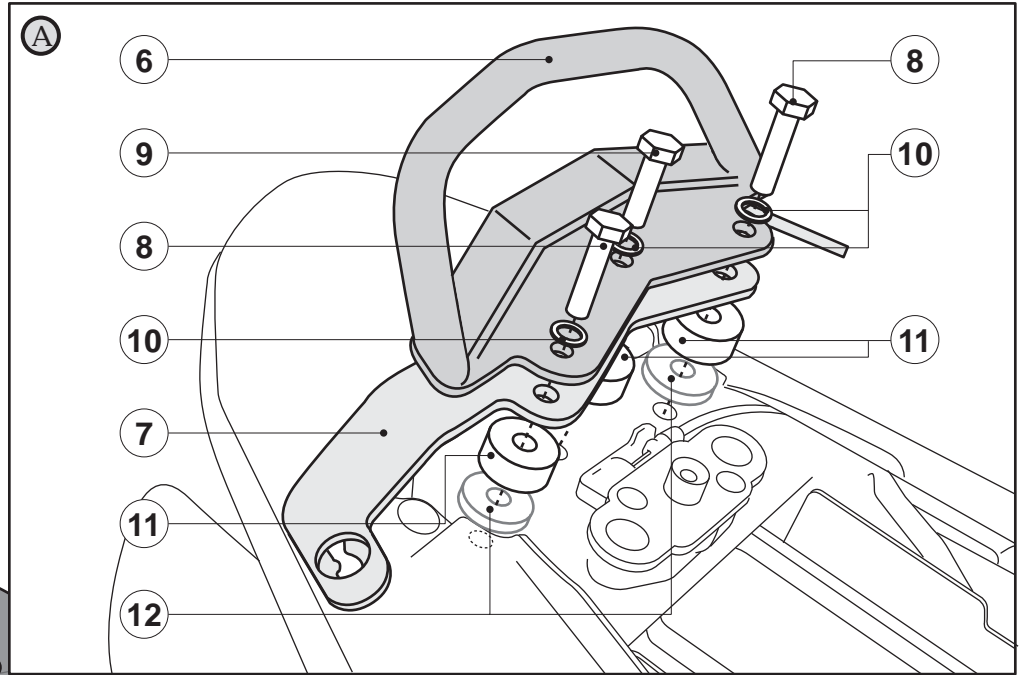

1

Kofferträger  
Side Bracket

KFT.05.517.901/902 01

Anzahl/ Pcs. 2(L/R)

2

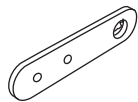
Befestigungsblech  
Fixing Lug

KFT.05.517.002 00

Anzahl/ Pcs. 2

6

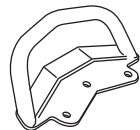
Haltegriff  
Grip

KFT.05.517.910 00

Anzahl/ Pcs. 1

10

Unterlegscheibe  
Washer

A 8,4 DIN 125

Anzahl/ Pcs. 3

13

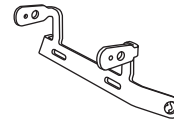
Querverbinder  
Cross Girder

KFT.05.517.003 00

Anzahl/ Pcs. 1

17

Linsenkopfschraube  
Lenshead Screw

schwarz/black

M5 x 16 ISO 7380

Anzahl/ Pcs. 2

3

Befestigungsblech  
Fixing Lug

KFT.05.517.001 00

Anzahl/ Pcs. 2

7

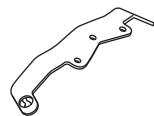
Querverbinder  
Cross Girder

KFT.05.517.005 01

Anzahl/ Pcs. 1

11

Distanzbuchse  
Spacer

Da:30 Di:8,4 h:13

Anzahl/ Pcs. 3

14

Sechskantschraube  
Hexagon Screw

M6 x 20 DIN 933

Anzahl/ Pcs. 2

18

Mutter mit Bund,  
selbstsichernd  
Lock Nut with Flange

M5 DIN 6927

Anzahl/ Pcs. 2

4

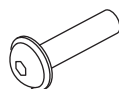
Linsenkopfschraube  
Lenshead Screw

M6 x 35 ISO 7380

Anzahl/ Pcs. 4

8

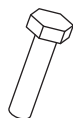
Sechskantschraube  
Hexagon Screw

M8 x 45 DIN 933

Anzahl/ Pcs. 2

12

Distanzbuchse  
Spacer

Da:30 Di:8,4 h:5

Anzahl/ Pcs. 2

15

Unterlegscheibe  
Washer

A 6,4 DIN 9021

Anzahl/ Pcs. 2

19

Kabelverlängerung,  
2-polig  
Twin Cable Extension

Kabelverlängerung 100 mm

Anzahl/ Pcs. 2

21

Kabelverbinder  
Cable Connector

STV.00.025.RD

Anzahl/ Pcs. 4

5

Mutter mit Bund,  
selbstsichernd  
Lock Nut with Flange

schwarz/black

M6 DIN 6927/b

Anzahl/ Pcs. 4

9

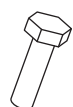
Sechskantschraube  
Hexagon Screw

M8 x 40 DIN 933

Anzahl/ Pcs. 1

Distanzbuchse (12) entfällt  
beim Gebrauch vom Original  
Topcase-Träger

Don't use spacer (12)  
while OEM Topcase Carrier  
is mounted.

**SW-MOTECH**  
engineering for motorbikes  
KFT.05.517.100

16

Mutter mit Bund,  
selbstsichernd  
Lock Nut with Flange

schwarz/black

M6 DIN 6927/b

Anzahl/ Pcs. 2

20

Schnellverschluss  
Quick Fastener

CAM.2312S21-12AHNV

Anzahl/ Pcs. 6

22

Sicherungsring  
Retaining Ring

CAM.2312S10/1BP

Anzahl/ Pcs. 6