



## Fitting Instruction

Part-No. : **100T041T**  
 Product : **Steering damper**  
 Vehicle Manufacturer : **Triumph**  
 Model (Type) : **Street Triple 675 (D67LD) '08 -'12**  
                   **Street Triple 675 R (D67LD) '09 -'11** (only applicable with  
                   our handlebar clamping assy 127X080..)  
                   **Street Triple 675 R (D67LD) '12** (only applicable with our  
                   handlebar clamping assy 127T040..)

### Mounted Steering damper



#### Parts list:

1 steering damper, 70mm stroke	→ „A“	1 spacer Ø15 x 3,4 x 52	→ „G“
1 body clamp Ø22,3mm	→ „B“	2 corrugated washers M6	→ „H“
1 frame bracket, type T41	→ „C“	2 bolts M5 x 16	
1 slider-tube clamp, Ø50mm	→ „D“	2 bolts M6 x 65	
1 stainless chamfered bush, Ø15 x 4	→ „E“	1 bolt M8 x 30	
1 O-Ring, 12x3mm	→ „F“	1 bolt M8 x 80	

#### **Check for completeness**

**Important!** If you are not a trained motorcycle mechanic stop now. Ask a local motorcycle shop to do the work for you.

Please make sure that the steering damper is not used as a steering stop! Check all bolt connections at last and start with lowest damping for first ride!

If not otherwise mentioned, the following tightening torques are recommended: M5 = 5Nm/3.7lbf ft, M6 = 10Nm/7.4lbf ft, M8 = 20Nm/14.8lbf ft

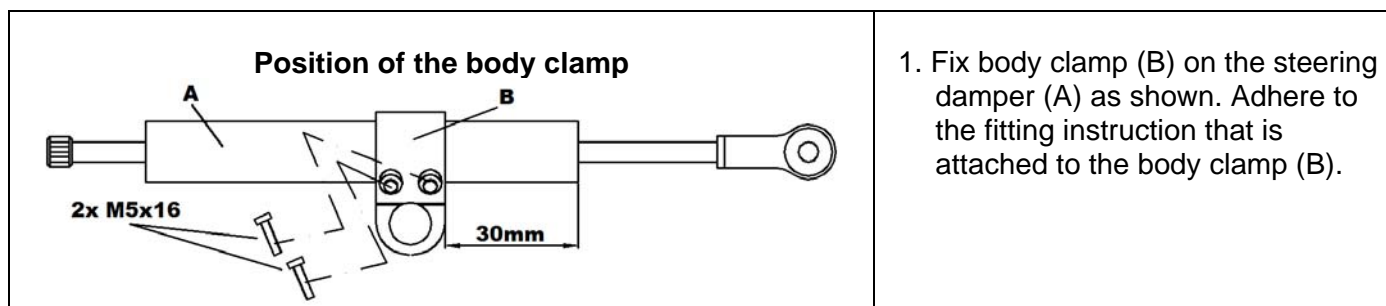

### Fitting the frame bracket

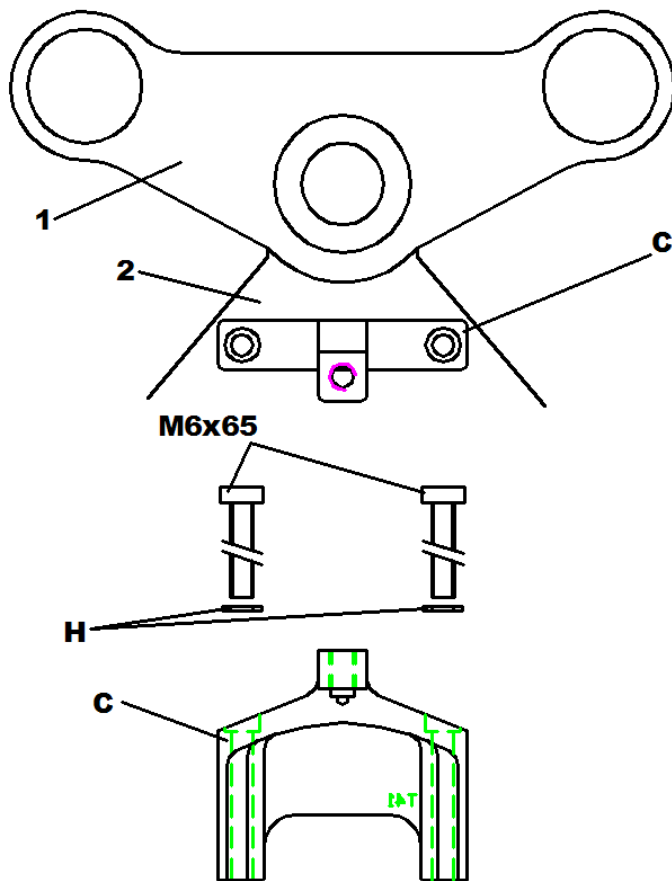

2. Remove the bolts of the tank to frame connection. Then mount the frame bracket (C) with bolts M6x65 and corrugated washers (H) on the frame (2), as shown.

### Fitting the slider-tube clamp

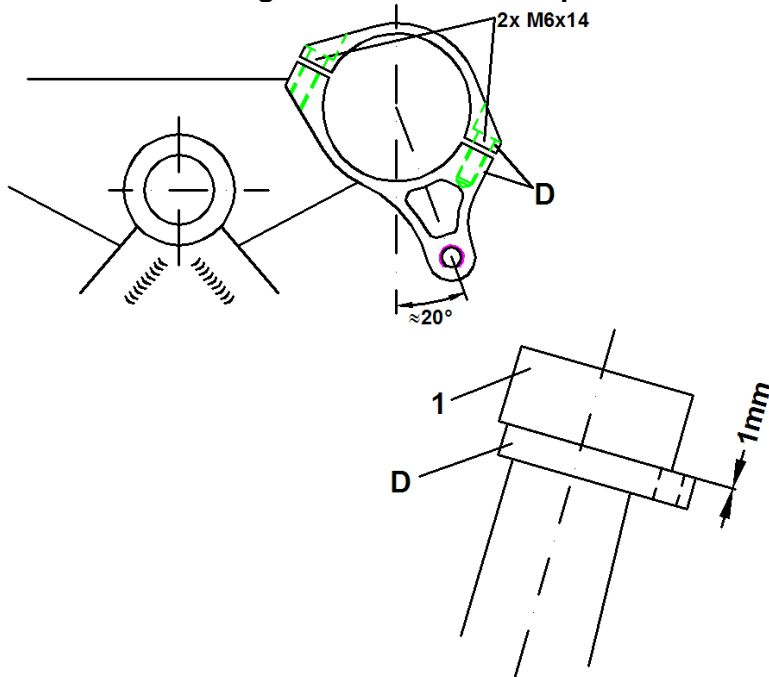

3. Mount the clamp (D) with screws M6x14 on the slider tube, underneath the top yoke (1). Adjust it as shown but do not tighten it too strong, so it may be necessary to adjust the damper by turning the clamp slightly.

### Fitting the steering damper

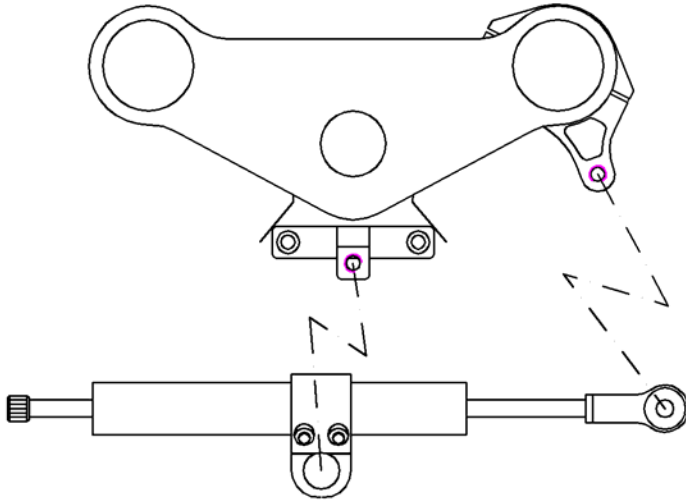

### Fitting the body clamp

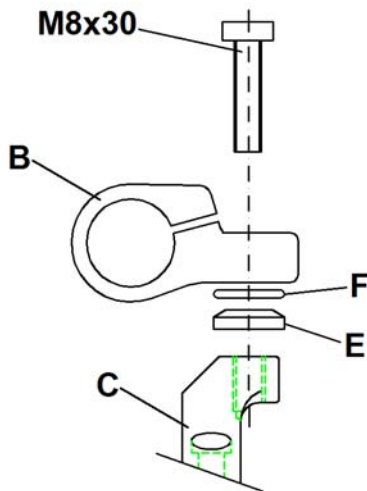

### Fitting the damper rod

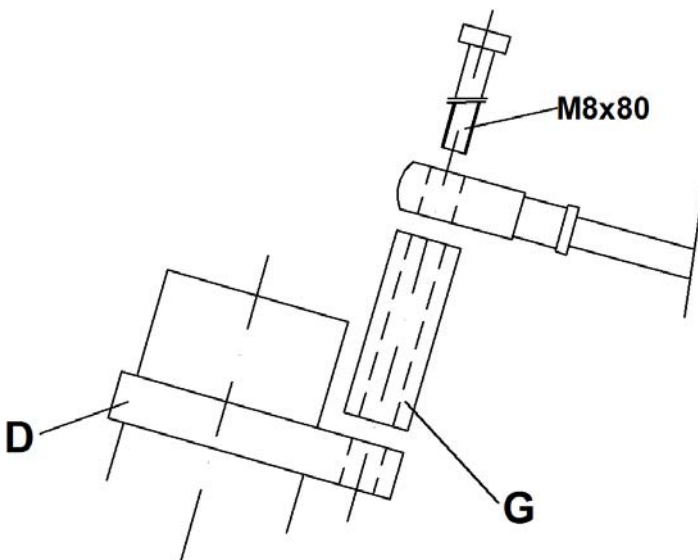

4. Fit the body clamp (B) first with bolt M8x30, stainless chamfered bush (E) and O-Ring (F) on the top frame bracket (C) as shown.

5. Then mount the damper rod with bolt M8x80 and bush (G) on the slider-tube clamp (D) as shown. Adjust the damper by turning the clamp.

**Please make sure that the steering damper is not used as a steering stop! Check all bolt connections at last and start with lowest damping for first ride!**



**LSL-Motorradtechnik GmbH • D-47809 Krefeld**

**[www.lsl.eu](http://www.lsl.eu)**