



Fitting Instruction

Part-No. : **110K086 & 110K086SW**
Product : **Rear Set**
Vehicle Manufacturer : **Kawasaki**
Model : **W 650**

Important:

Read these instructions carefully and mind all warnings and tips. You should do this work only if you're qualified; otherwise we recommend this mounting to be done by a qualified workshop. Improperly mounting of this kit can reduce the driveability of the motorcycle and may be a risk to your health and life.

Special works are marked with the following signs. Please take special care on these works.



Warning! Important mounting instruction. It shows risks to your life and health.



Tips for mounting and maintenance or to avoid damage.

Fitting:

Remove foot pegs, brake pedal and shifter. The following original parts will be used for your new rear set: Brake pedal's clamping bolt and adjusting bolt with counter nut.



Rear sets are pre-assembled but all screws are not tightened! Always use locknuts or proper amount of medium thread-locking adhesive (e. g. Loctite 243). All details of assembling are shown on the backside drawing. All parts are welded into their bags as they belong together.

The tightening torques for connections to the frame refers to the manufacturer's instructions. Use the following torques for all other bolted connections:

M5	=	6Nm	=	4.43lbf ft
M6	=	10Nm	=	7.38lbf ft
M8	=	20Nm	=	14.75lbf ft
M10x1.25	=	30Nm	=	22.13lbf ft



After installing your new rear set, **test brake and gear shifting indoor. If anything is not operating properly or braking efficiency is poor, testing on the road may result in death or serious injury!**

Maintenance:

 Periodically proof all functions during service intervals. Use **particle free (no MoS₂)** lithium or barium soap grease to maintain lever bushings.

Mount peg adapter and bushing as shown in separate drawing for peg adapter. **This needs to be done before fixing the hanger!**

Use adjusting bolt (M6x25) and counter nut from original brake pedal

Mount new brake pedal with the bolt from original brake pedal. **Place washer Ø16xØ22x1 between pedal and frame!**

Remove kickstarter and close bore with the attached plug. **It is no additional sealing required!**

Fix corrugated brake pedal knob with countersunk M6x20

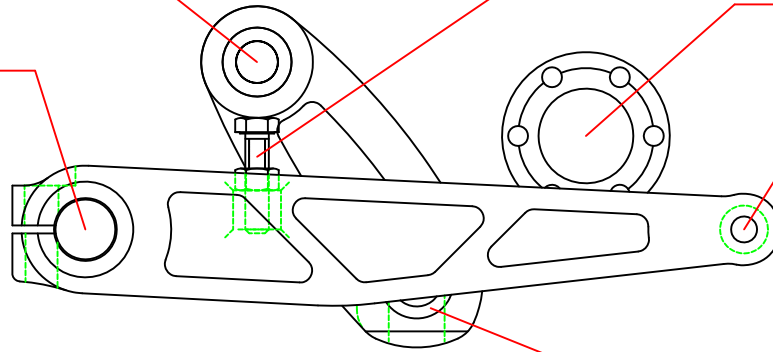

Fix hanger with M12x1,25x40. **Assure that tongue and groove are aligned!**

Fix the ball joint with M6x16 on the shifter's inside

Counter nut M6LH

Counter nut M6

Mount peg adapter and shifter as shown in separate drawing for peg adapter. **This needs to be done before fixing the hanger!**

Fix the left hand ball joint with M6x18 on the lever's outside

Fix shifter knob with M6x16

Fix hanger with M12x1,25x40. **Assure that tongue and groove are aligned!**

Mount gearbox lever with M6x22 and washer onto the shifting axle

Rear Set
Kawasaki W650

Linke Seite / left side

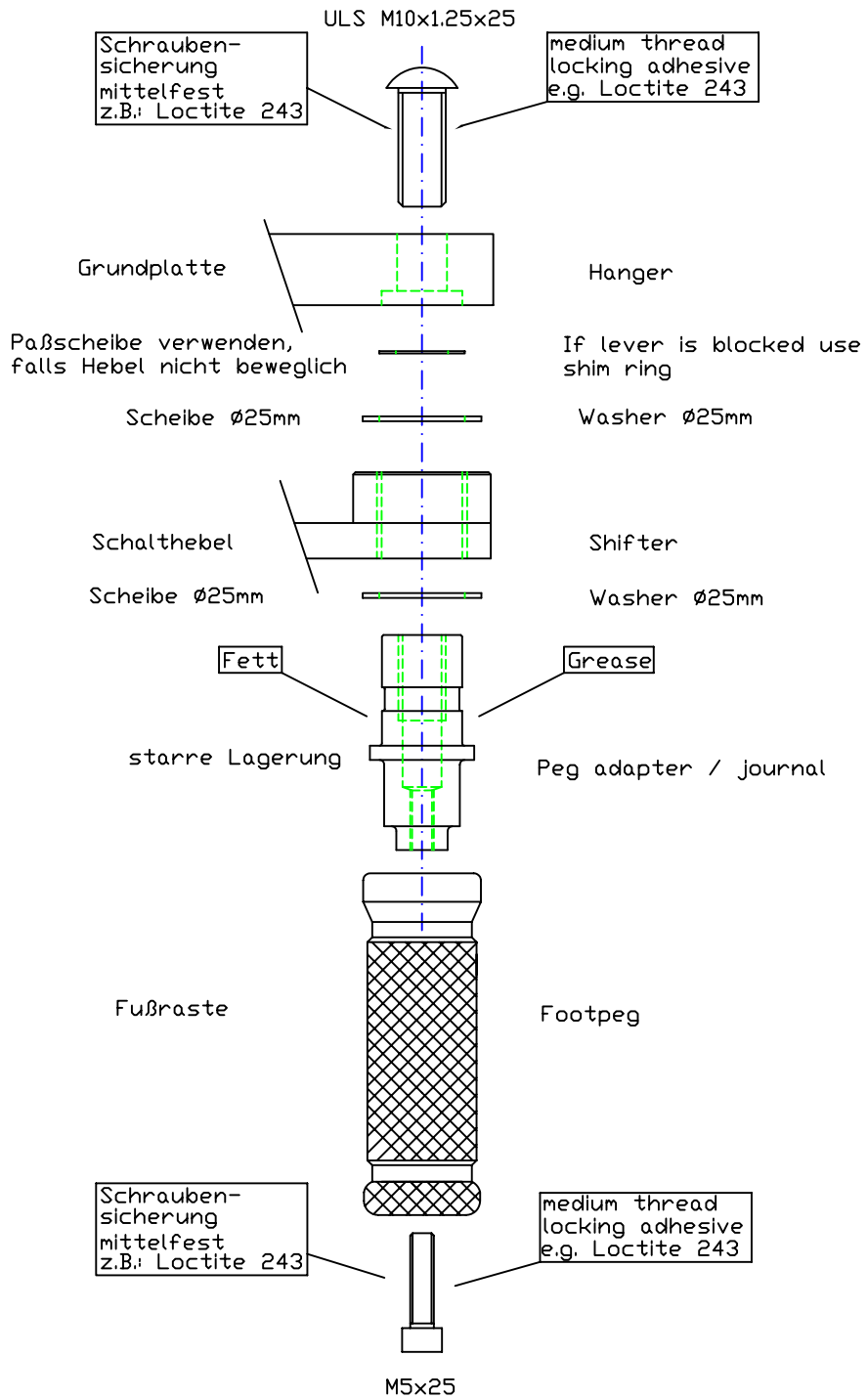

Rechte Seite / right side

