

# Instruction manual for the m-Wave® turn signal relay

## Exclusion of liability

DEVICE HOUSINGS AND ALL OTHER DELIVERED PARTS MUST NOT BE OPENED OR DISMANTLED. IN CASE OF NON-COMPLIANCE ALL GUARANTEE CLAIMS BECOME INVALID. MOTOGADGET ACCEPTS NO LIABILITY FOR DIRECT OR INDIRECT DAMAGE OR SUBSEQUENT DAMAGE OF ANY KIND RESULTING FROM THE USE, INSTALLATION OR CONNECTION OF THE M-WAVE OR OTHER DELIVERED EQUIPMENT. THIS EXCLUSION OF LIABILITY PARTICULARLY INCLUDES DAMAGE TO PERSONS, MATERIAL LOSSES AND FINANCIAL DAMAGES. THE USE OF THE DEVICE IN AREAS OF PUBLIC TRAFFIC IS UNDERTAKEN AT THE USER'S OWN RISK.

## Application area

The m-Wave is a electronic flasher relay with fade in/fade out effect. The device can only switch resistive loads like light bulbs or LED lamps up to a maximal current of 7A (equivalent to 4 light bulbs with 21W). For a proper operation a minimum load of 1W is necessary. Some LED indicator lights have a power consumption below 1W. In this case the delivered load resistors have to be connected in parallel to on an indicator light of each side. The resistor stays cold during operation and can be integrated into the connecting cables. The device is not suitable to switch capacitance loads (horn) or inductive loads (coils, relay). The ambient temperature must not below -20° (-4°F) and not exceed +85° (185°F).

## Power supply

The m-Wave can operate in a voltage range from 5,5V to 18V DC and is suitable for 6V and 12V vehicle power systems. Operating the device without a battery, for example, using a direct connection to the vehicle's generator is not envisaged or recommended. The device will not switch if used with a voltage below 5,5V. A voltage higher as 18V will destroy the device. Also a short circuit (operate without a load) will destroy the device. Do not use the device if it is not working properly (indicators are permanently illuminate).

## Replacing the OEM Turn signal relay by the m-wave

Turn vehicle power off.

Connect the cable named 49 or B from the OEM turn signal relay socket with the m-wave red cable. Connect the cable named 49a or L from the OEM turn signal relay socket with the m-wave black cable. The remaining third socked cable (if existing) will be not used and insulated after cutting off the socked. Solder or crimp the cable in a proper way. Insulate the connection joint with shrinking tube.

## Installing the m-wave in a self-made wiring loom

Please consider following recommendations for choosing the place of attachment:

- Spray water protected
- sufficient distance to hot engine or exhaust parts (max. ambient temperature in operation is 85°C)
- minimum distance of 30 cm to sources of electromagnetic interferences (ignition coils, high tension cables).

Important is a sufficient strain relief and bend protection of the connection cables. At mechanical stressed areas an additional insulating is necessary to prevent damage at the cable insulation. It must no mechanical stresses and strains act on the device (pull, push or shock forces). The device has to be attached direct at the cable loom with plastic cable ties.

## Connection

Make sure you connect the m-Wave in the right polarity. Connect the red cable in direction +12V and the black cable in direction earth. A short operation in reverse polarity (<5s) will not damage the m-Wave. In this case the indicators will permanently illuminate. An operation longer than 5 seconds in reverse polarity will destroy the device. Please check the polarity of the connection cables with a voltmeter before connection and operation. Remove the vehicle battery or interrupt its connection to the vehicle electrical system before starting the electrical connection of the m-Wave. Use the original vehicle wiring diagram. Make sure you accomplish your work in a proper way.

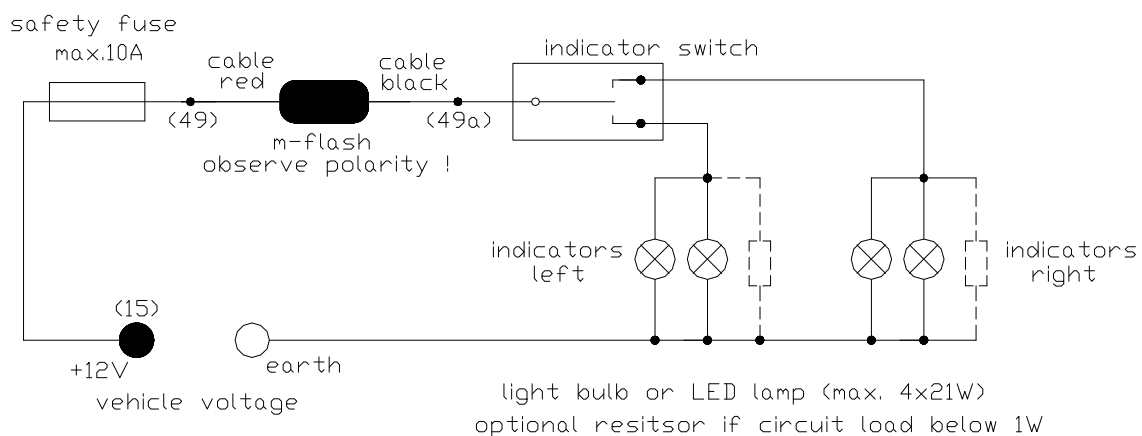

**ATTENTION!** THE MINIMAL SUPPLY CABLE WIDTH IS 0,75MM². YOU MUST FUSE THE +12V POWER SUPPLY CABLE WITH A 10A SAFETY FUSE. IF THE DEVICE WILL BE USED WITHOUT FUSE, DAMAGE AT THE CONNECTING CABLE OR THE M-WAVE ITSELF CAN CAUSE A SHORTCUT AND A CABLE FIRE. THERE MAY BE A RISK OF YOUR LIFE! IF YOU ARE NOT CAPABLE TO CONNECT THE DEVICE PROPERLY, LET THE PROFESSIONAL MOTORCYCLE TECHNICIAN DO THE JOB.