

MONTAJE, ASSEMBLY, MONTAGE, MONTAGGIO

REF. HONDA (7 TORNILLOS, 7 SCREWS) (7 SCHRAUBEN, 7 VISSÉS)

Nº1  M4X35 DIN 912 1UDS

Nº2  M4X35 DIN 7991 2UDS

Nº3  M6X25 DIN 912 4UDS

 ALLEN: 5, 3, 2'5



¡ TORQUE, PAR DE APRIETE, LOCKED TORQUE !

M6 - 6 Nm. M4 - 4Nm.

NOTA: No garantizamos contra la rotura debido al sobreapretamiento de los tornillos.

NOTE: We do not guarantee against breakage due to overtightening of screws.

ATTENTION: Nous ne garantissons pas contre la rupture en raison du surresserrement de vis.

ATTENZIONE: Noi non garantiamo contro rottura a causa di stringere eccessivamente di viti.

ACHTUNG: Wir übernehmen keine Haftung bei Brüchen durch zu festes Anziehen der

Schrauben

Motoplastic S.A.
Molino de la Sal, 1
08400 Granollers
Barcelona, España
Tel: 93.849.06.33 Fax: 93.849.09.88
E-mail: info@motoplastic.com

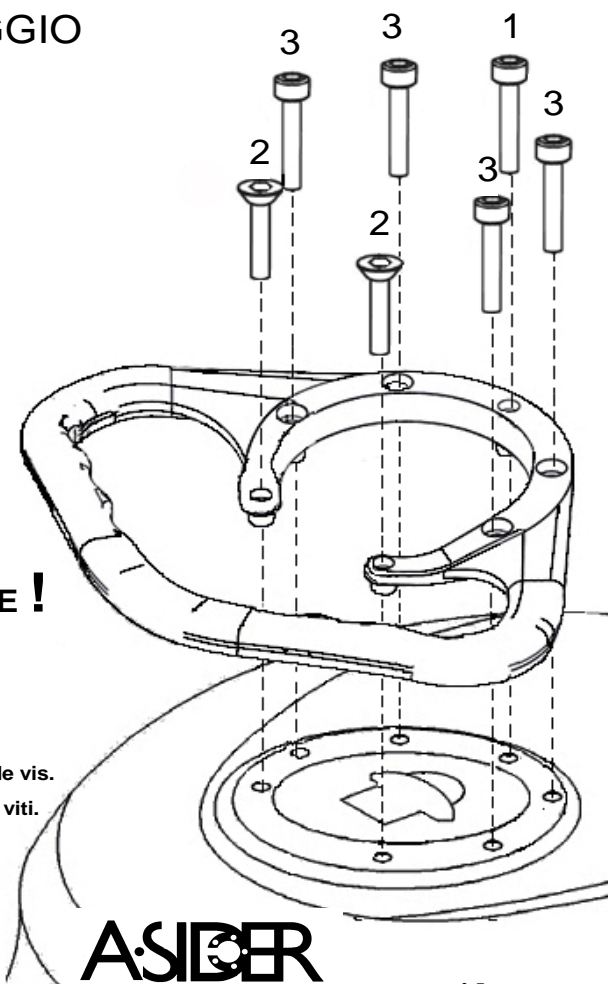

MONTAJE, ASSEMBLY, MONTAGE, MONTAGGIO

REF. HONDA (7 TORNILLOS, 7 SCREWS) (7 SCHRAUBEN, 7 VISSÉS)

Nº1  M4X35 DIN 912 1UDS

Nº2  M4X35 DIN 7991 2UDS

Nº3  M6X25 DIN 912 4UDS

 ALLEN: 5, 3, 2'5



¡ TORQUE, PAR DE APRIETE, LOCKED TORQUE !

M6 - 6 Nm. M4 - 4Nm.

NOTA: No garantizamos contra la rotura debido al sobreapretamiento de los tornillos.

NOTE: We do not guarantee against breakage due to overtightening of screws.

ATTENTION: Nous ne garantissons pas contre la rupture en raison du surresserrement de vis.

ATTENZIONE: Noi non garantiamo contro rottura a causa di stringere eccessivamente di viti.

ACHTUNG: Wir übernehmen keine Haftung bei Brüchen durch zu festes Anziehen der

Schrauben

Motoplastic S.A.
Molino de la Sal, 1
08400 Granollers
Barcelona, España
Tel: 93.849.06.33 Fax: 93.849.09.88
E-mail: info@motoplastic.com

